

SP904 - SECURITY UPGRADE PACK FOR VT904

Includes;

- An engine starter immobiliser relay kit (For engine starter immobilisation via the APP)
- A vehicle's car alarm connection kit (Sends the SOS text alert)
- An 'SOS' emergency button (Sends the SOS alert text alert) NOTE: 24 volt vehicles – relays not supplied.

CRITICAL INFORMATION ON IMMOBILISER

The immobiliser should only be connected to starter motor.

The immobiliser should only be activated once the vehicle is stationary.

Immobilising a moving vehicle is dangerous and could cause injury or death.

The user-operator is responsible for ensuring it is safe to activate the remote immobilisation of the vehicle.

The immobilisation should be professionally installed and checked for safe operation.

INSTALLATION & WIRING GUIDE

Use in conjunction with the 'Activation Manual' supplied with the VT904 GPS tracker

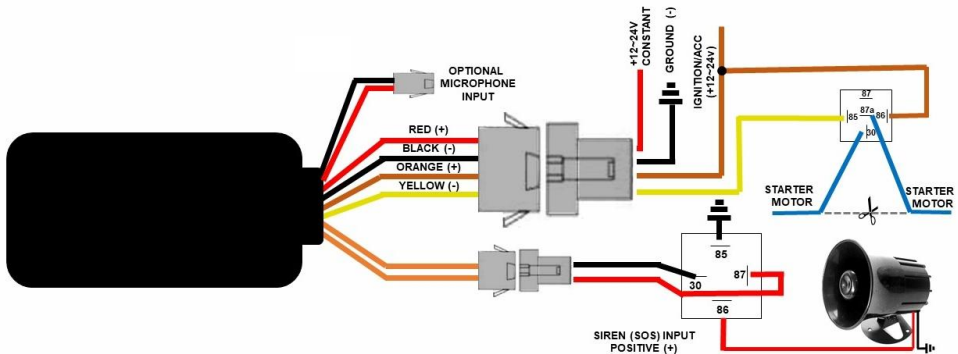

ENGINE STARTER IMMOBILISER

To prevent engine starting, as a means of protection against theft or non-authorized use, only the starter motor is to be immobilised as this does not affect the safe operation of the vehicle. Turn ON/OFF with the mobile APP or text command.

IMPORTANT NOTE: . REQUIRES INSTALLATION FROM QUALIFIED PROFESSIONAL

VT904 and SP904 must be tested to ensure correct and safe operation when installed

CAR ALARM SIREN & SOS BUTTON INPUT

The wiring diagram above shows how a (+) positive trigger Mongoose car alarm siren is connected. If connecting to a negative trigger alarm system, connect pin 85 to constant (+) positive supply and pin 86 to the negative trigger of the siren.

NOTE: The siren input does not provide for pulsed siren or horn triggers. **USE THE MOBILE APP TO TEST THE SP904 INSTALLATION**

It is critical that the SP904 options are tested by the tracker's owner/user by using the **4G MONGOOSE GPS** mobile APP as detailed in the VT904 manual supplied with the tracker. **IMPORTANT NOTICE:** VT904 must 4G Signal and have GPS signal and will wait till it can confirm tracker speed drops below 20km per hour to activate IMMOBILISATION RELAY. If the VT904 does not have GPS signal it cannot activate. Low 4G coverage can delay activation/deactivation of relay.

STARTER IMMOBILISATION ****Ensure vehicle is STATIONARY****

- Open the mobile APP then logon.
- Check to ensure that the vehicle is stationary
- Select 'menu' and then 'text commands'
- Select the immobiliser command and choose 'ON'.
- The APP will ask for confirmation to prevent accidental immobilisation.
- Test immobilisation by attempting to start the engine.
- Assuming immobilisation is successful, re-engage the starter by sending the 'OFF' text command. Test for correct operation by starting the engine.

SOS or CAR ALARM TEXT ALERT

When the alarm Siren is activated, or the SOS button is pressed, the VT904 will alert the owner and authorised mobile phones with an 'SOS' text message.

There is a built-in 4~5 second delay before the alert is sent to allow for false alarms and for the vehicle owner to cancel the alarm sounding.

Arming/disarming and pre-intrusion chirps do not cause an alert.

YOU must send TEXT command to VT904 to set up 2 phone numbers that the VT904 will text when SOS- SIREN alert is triggered. Must enter 2 x phone numbers

SEND TEXT to VT904 **sos,XXXXXXXXXX,XXXXXXXXXX**

XXXXXXXXXX = mobile phone numbers that you want VT904 to send SMS Alert to.

Reply from VT904 **SOS! S1:XXXXXXXXXX S2:XXXXXXXXXX**